



US006196890B1

(12) **United States Patent**
Amaral

(10) **Patent No.:** **US 6,196,890 B1**
(45) **Date of Patent:** **Mar. 6, 2001**

(54) **YO-YO AND METHOD FOR ITS MANUFACTURE**

(75) Inventor: **Leonard R. Amaral**, Rehoboth, MA (US)

(73) Assignee: **Yomega Corporation**, Fall River, MA (US)

(*) Notice: Subject to any disclaimer, the term of this patent is extended or adjusted under 35 U.S.C. 154(b) by 0 days.

(21) Appl. No.: **09/244,798**

(22) Filed: **Feb. 5, 1999**

Related U.S. Application Data

(63) Continuation-in-part of application No. 09/097,520, filed on Jun. 15, 1998.

(51) **Int. Cl.**⁷ **A63H 1/30; A63H 1/06**

(52) **U.S. Cl.** **446/250; 446/248**

(58) **Field of Search** 446/236, 247, 446/248, 250, 251, 252, 255

(56) **References Cited**

U.S. PATENT DOCUMENTS

59,745	*	11/1866	Haven et al.	446/250
179,377	*	6/1876	Weber	446/250
1,006,840	*	10/1911	Floto	446/250
3,175,326	*	3/1965	Isaacson	446/250
3,653,148	*	4/1972	Finkel	446/255
3,805,443	*	4/1974	Duncan, Jr.	446/250
5,017,172	*	5/1991	Siefert	446/250
5,100,361	*	3/1992	Kuhn et al.	446/250

5,254,027	*	10/1993	McAvoy, Jr.	446/250
5,813,898	*	9/1998	Van Dan Elzen et al.	446/250
6,004,183	*	12/1999	Dixon et al.	446/250
6,077,145	*	6/2000	Ma	446/250
6,080,035	*	6/2000	Pekarsky et al.	446/250
6,080,036	*	6/2000	Adler	446/250

FOREIGN PATENT DOCUMENTS

399370	11/1932	(BE)	.
197 31 087	9/1997	(DE)	.
WO9965581	12/1999	(WO)	.

* cited by examiner

Primary Examiner—D. Neal Muir

(74) *Attorney, Agent, or Firm*—Kilpatrick & Lockhart LLP

(57) **ABSTRACT**

A metal yo-yo embodies a construction in which each of the halves of the yo-yo body is formed from a disc and a hub that are made separately and secured to each other in an integral structure. The discs can be die cut from sheet material and may be deformed about the peripheral margin to define a dished configuration. The hub is inserted into the center hole of the disc and the two are assembled together in a swaging operation that constricts the metal of the disc about a portion of the hub. A pair of such yo-yo halves are connected together by an axle assembly that includes a bearing to facilitate extended spin time for the yo-yo. The yo-yo construction and method of fabrication provides substantial economies in the manufacture of metal yo-yos. In another aspect of the disclosure, the inwardly facing surfaces of the yo-yo halves may be formed to define an annular recess that cooperates with the yo-yo string in a manner that affects retrieval of the yo-yo.

7 Claims, 9 Drawing Sheets

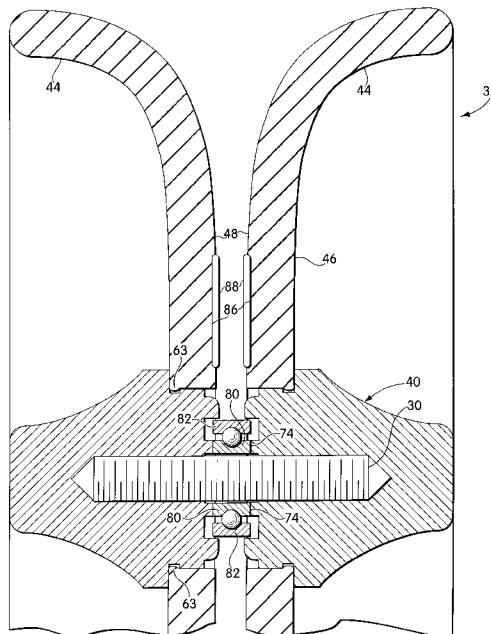

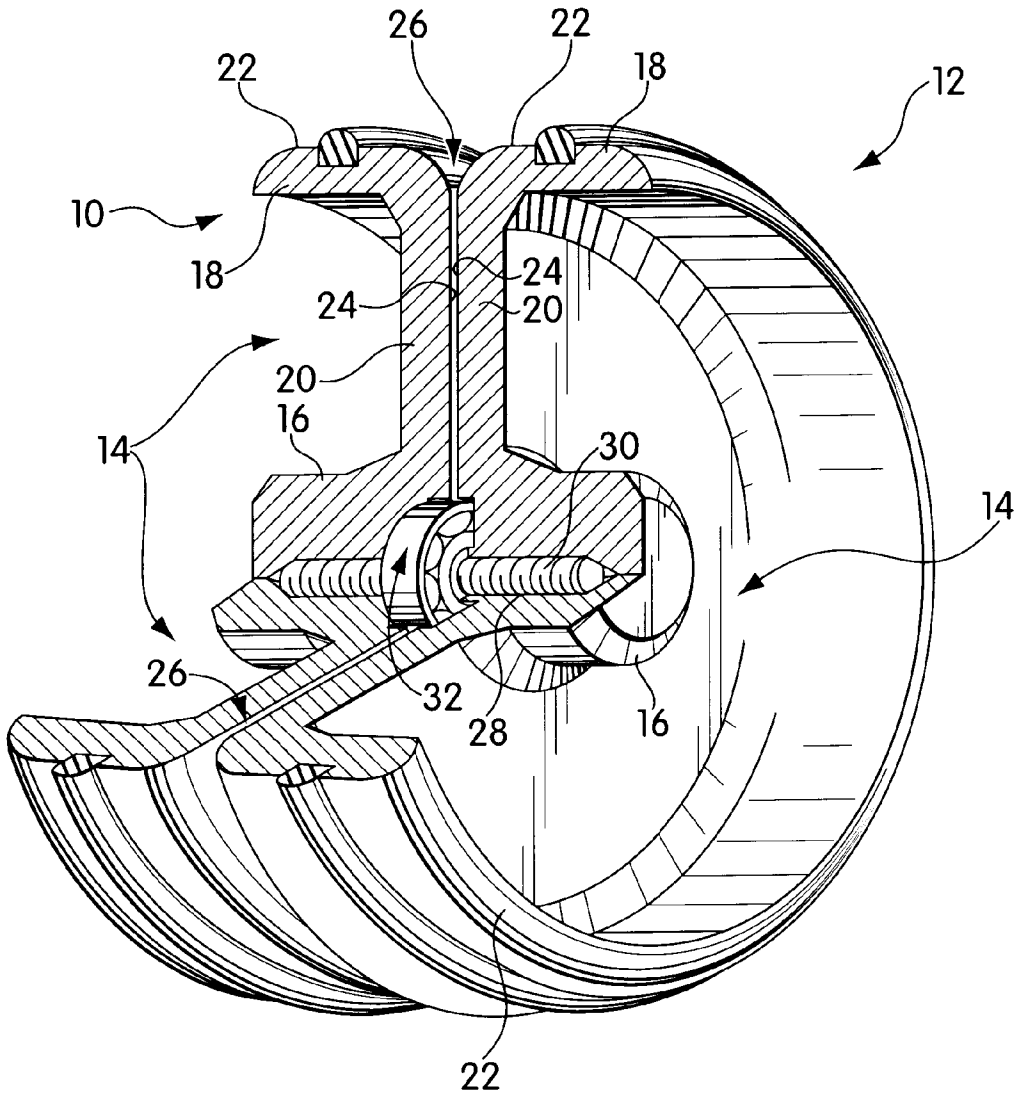

Fig. 1
PRIOR ART

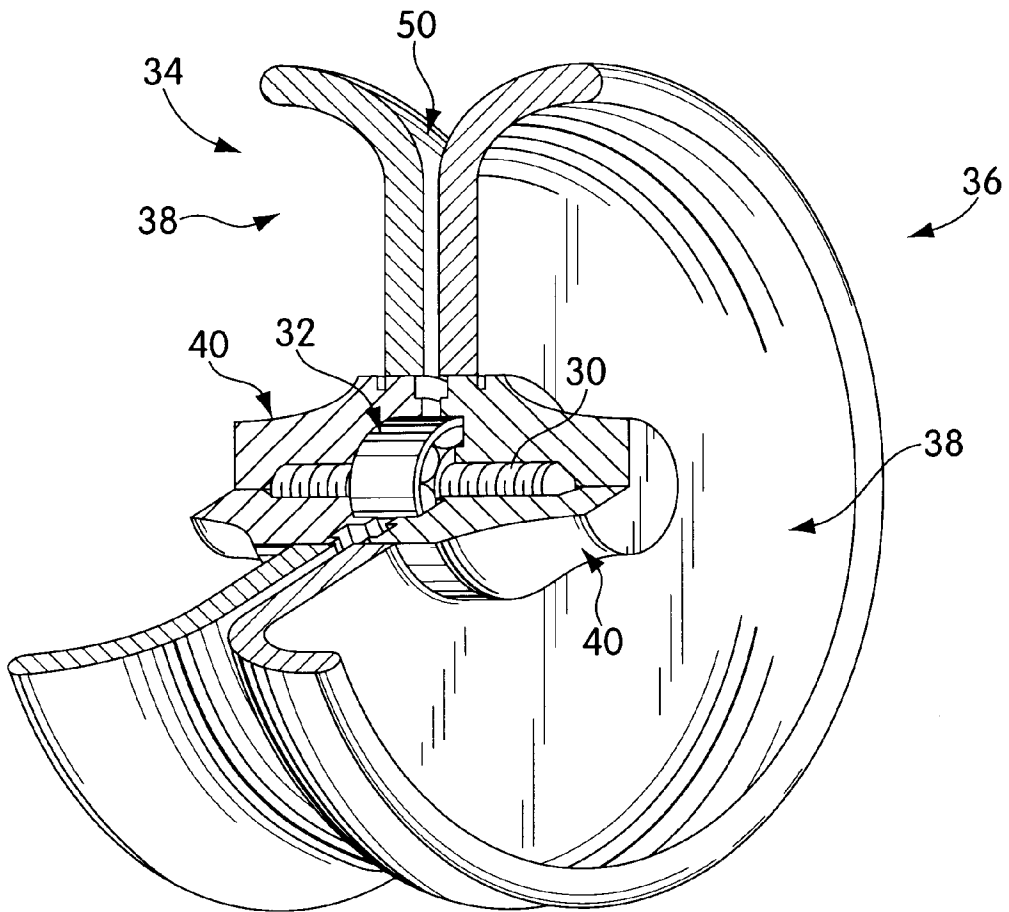

Fig. 2

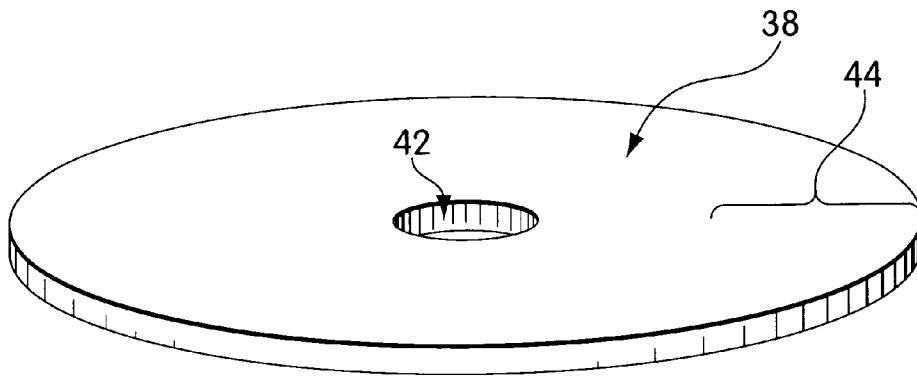

Fig. 3

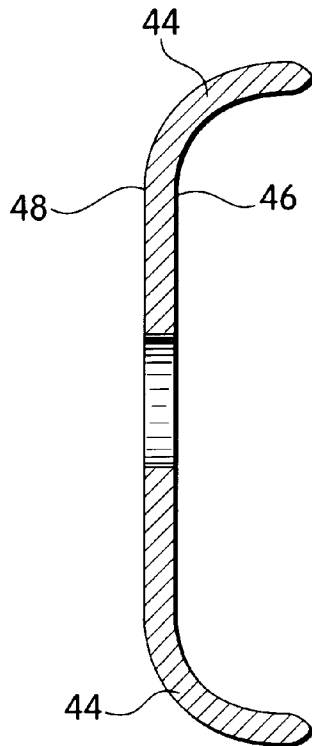

Fig. 4

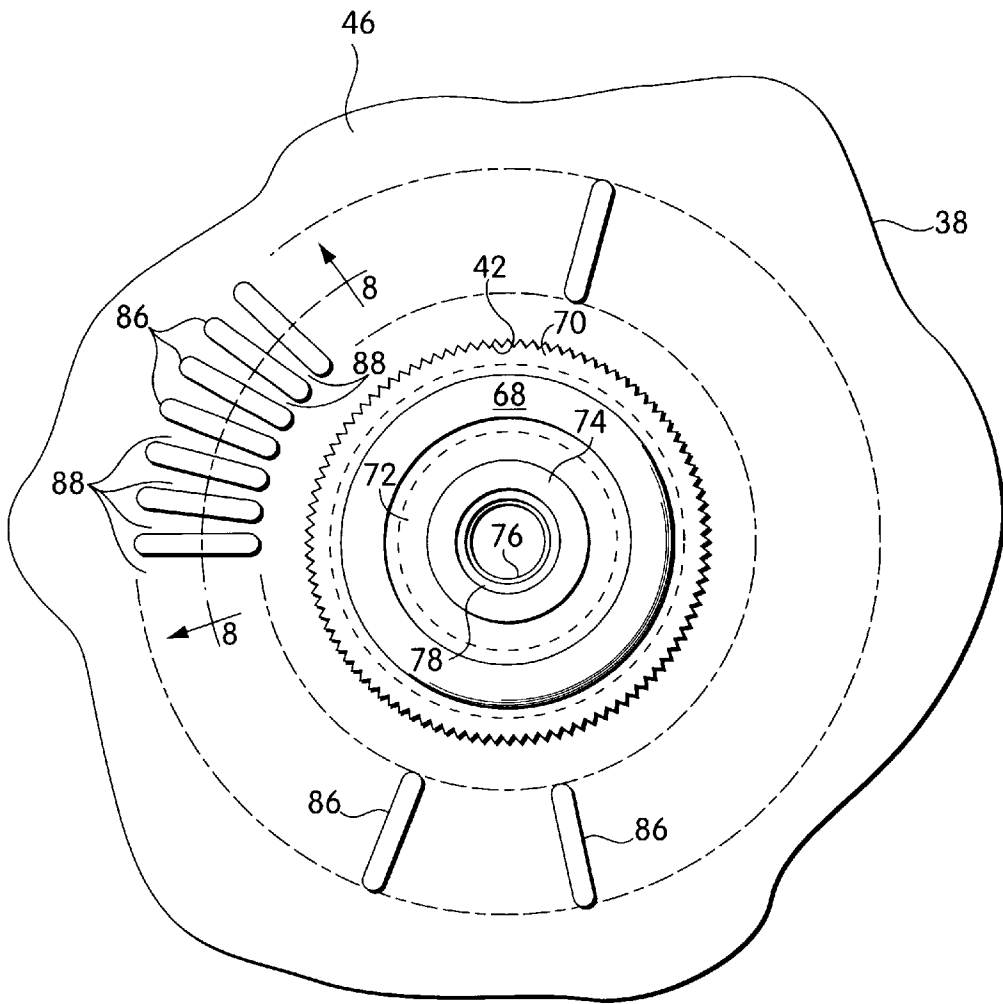

Fig. 7

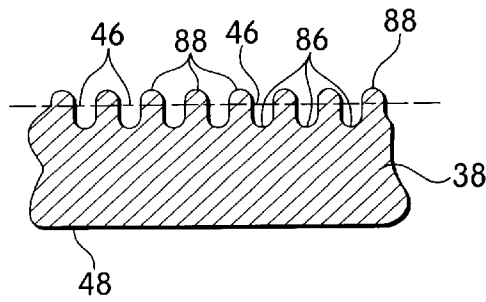

Fig. 8

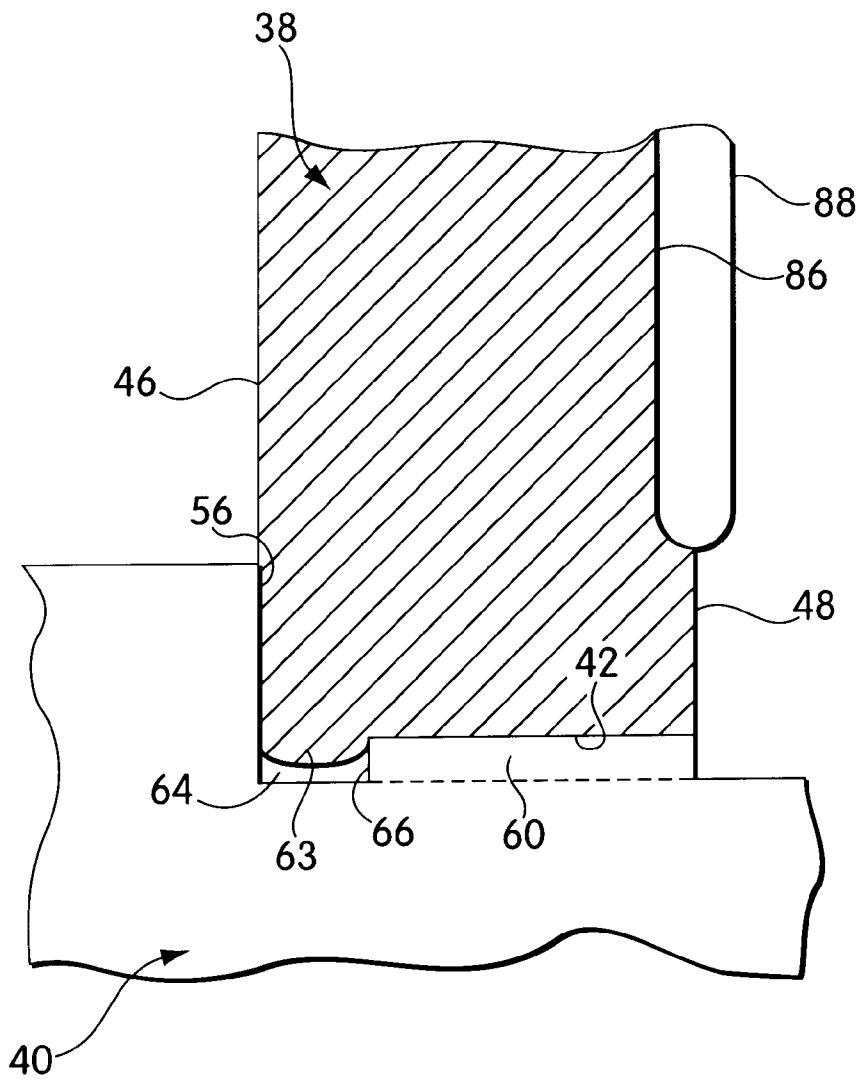

Fig. 10

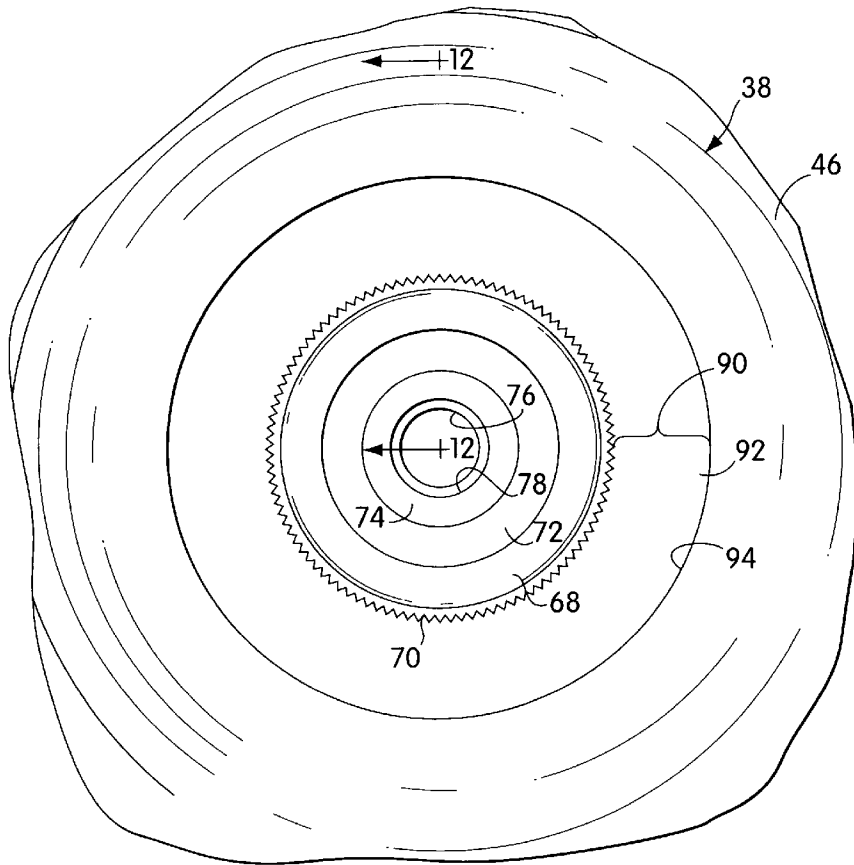

Fig. 11

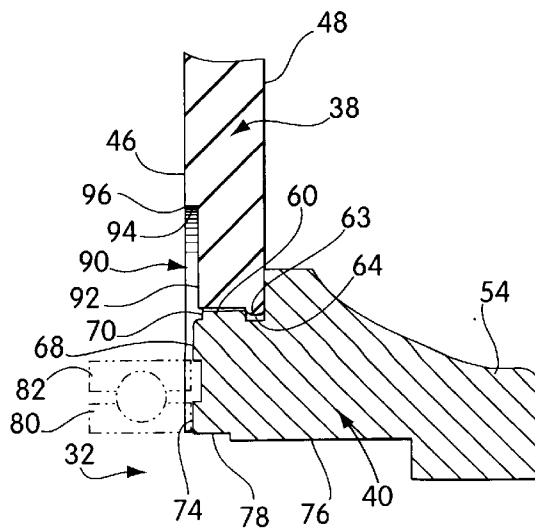

Fig. 12

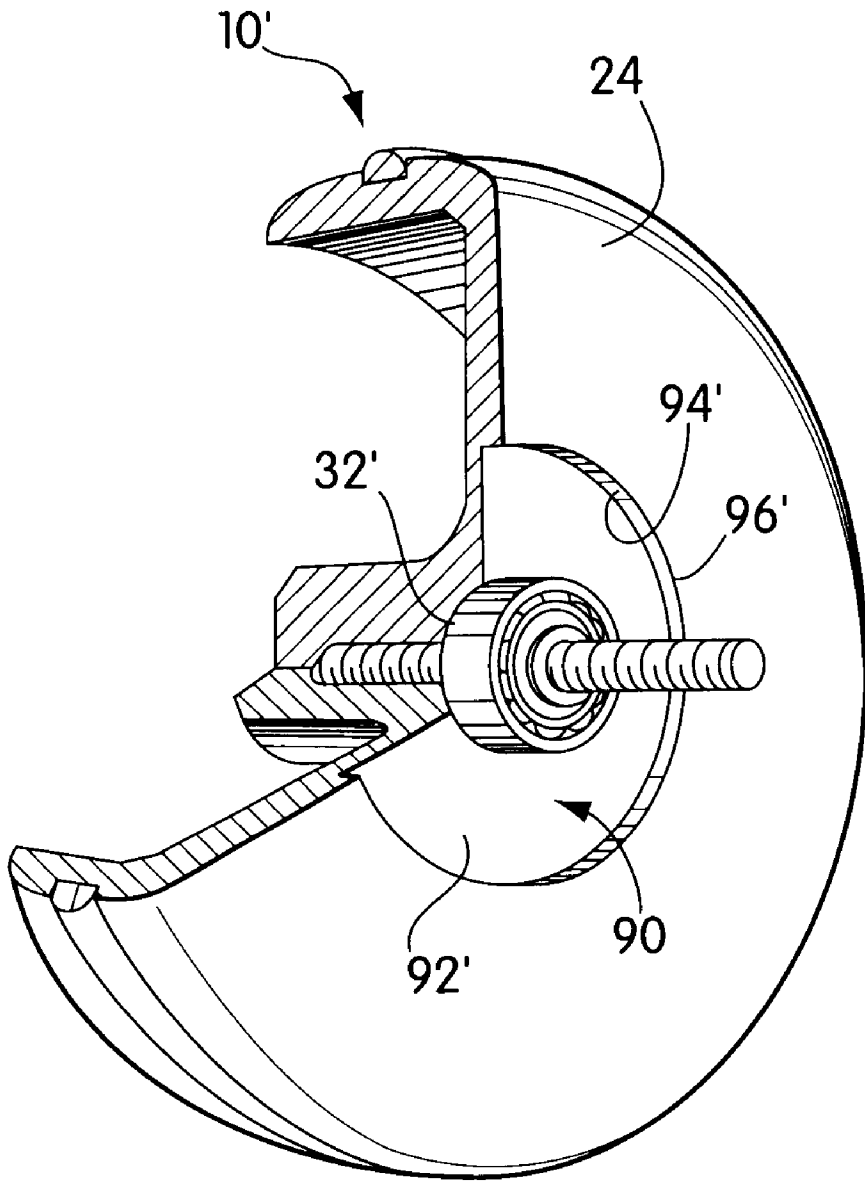

Fig. 13

YO-YO AND METHOD FOR ITS MANUFACTURE

RELATED APPLICATION

This application is a continuation-in-part of U.S. application Ser. No. 09/097,520 filed Jun. 15, 1998.

FIELD OF THE INVENTION

This invention relates to yo-yos, including yo-yos fabricated from metal.

BACKGROUND OF THE INVENTION

Yo-yos most commonly are made from wood or from a molded plastic as the principal material of construction. Yo-yos made from different materials present a different feel to the yo-yo player, some players preferring the feel of one over the other. Some yo-yos have been made from metal which presents still another feel that may be preferred by some players. Few metal yo-yos have been commercialized, however, and, as to those, their availability has been limited possibly because the typical construction for such yo-yos is costly and is substantially more than that of a more conventional yo-yo made from plastic or wood. In one prior art construction, the metal yo-yo may be formed from aluminum by machining the yo-yo halves that will be assembled to form the yo-yo body in a milling machine from solid round aluminum bar stock. The entire yo-yo half is formed, in one piece, from the round aluminum bar stock. The end of the bar stock is milled to form the outer face of the yo-yo half by removing an annular region of material, leaving a center hub and a peripheral rim. The peripheral contour of the yo-yo half also may be milled, as may be the inner face of the yo-yo half. The milled piece then is cut-off from the round bar stock to a thickness appropriate for the yo-yo half. The inner face of the yo-yo half then is machined further by drilling and tapping a center hole along the central axis of the yo-yo half to accept the threaded end of an axle by which two yo-yo halves will be joined. After machining, the yo-yo halves then are individually polished and finished. Such one-piece yo-yo halves are made individually in a labor intensive process that is wasteful of material, all of which adds to the cost of the yo-yo.

Also among the desirable features of a yo-yo, especially for those users who wish to perform complex string tricks, is to provide a wide peripheral entry to the string slot between the yo-yo halves. Yo-yos having such a wide entry sometimes are referred to as having a "butterfly" configuration. While incorporating a butterfly configuration in a plastic injection molded yo-yo is simply a matter of configuring the mold for the yo-yo halves, the fabrication of a butterfly yo-yo from metal, using the prior art milling technique described above, presents additional difficulties in milling the peripheral surfaces as well as the inner surfaces of the yo-yo halves. Such milling results in still further waste of material and additional labor and other expenses attendant to finishing the surfaces of the yo-yo halves. The milled one-piece metal yo-yo involves a machining process that can be expected to leave marks and other irregular surface regions that should be finished to a smoother surface in order to accept a desired finish, such as anodizing or finishing graphics. The milled metal yo-yo halves do not lend themselves to mass finishing but, instead, must be finished individually, adding further to the cost of the yo-yo.

Also, among the significant features of a yo-yo is the manner in which the yo-yo engages the string to catch the

string to initiate the rewinding and retrieval of the yo-yo. The feel and responsiveness to the player's retrieval command (slackening the string to relieve it of all tension) is, in part, a matter of personal preference and may depend on the types of tricks to be performed. It is desirable for the yo-yo to catch the string in a consistently responsive manner in order to enhance the player's control over the yo-yo. In some cases, it may be preferred for the yo-yo to have a "hair trigger" response in which very slight manipulation of the string is required to cause the string to become caught in the yo-yo to effect the retrieval. Others may prefer a less sensitive trigger reaction in which a more distinct manipulation is necessary in order to initiate the retrieval. Regardless of the degree of responsiveness, it is important that the response is consistent so that the player can best control the yo-yo. A starburst pattern of radial ribs on the inwardly facing surface of the yo-yo halves has been used in order to enhance the ability of the yo-yo to catch the string when tension on the string is momentarily released. The use of a starburst pattern may tend to increase the immediacy of the response to the retrieval command. While the starburst pattern of ribs may facilitate catching of the string, some yo-yo players may not favor the use of ribs because they may not provide the desired feel and degree of responsiveness when retrieving the yo-yo.

It would be desirable to provide a metal yo-yo embodying a construction and method of manufacture that would reduce substantially the cost and ease of manufacture while providing a metal yo-yo with desirable characteristics, including the ability to form a butterfly yo-yo. It also would be desirable to provide a yo-yo configured to provide a desired feel and consistency during retrieval, for those players who may prefer not to use a yo-yo having the starburst rib configuration.

SUMMARY OF THE INVENTION

In accordance with one aspect of the invention, relating to metal yo-yos, each yo-yo half is made in two pieces, including a die cut, stamped body and a central hub attached to the body, both components being formed from a suitable metal. The body is made by die cutting an annular disc from a flat sheet of metal, the disc having a central hole adapted to receive the hub. A plurality of such discs can be die cut simultaneously from a larger sheet. Each flat disc then is subjected to a drawing process in which the disc is deformed about its periphery to form a flared rim that, in an assembled yo-yo, may cooperate with another such disc to define a wide butterfly entry to the string slot. A plurality of the drawn discs can be polished together in a mass polishing machine together with a suitable polishing grit. After polishing, the central hub is attached to the drawn disc. The hub is configured to facilitate its assembly with a drawn disc by fitting it into the central hole in the disc and then deforming some of the metal of the disc to constrict securely about the hub. The hub is designed for mass production on conventional equipment. The inwardly facing side of the hub is provided with a threaded bore adapted to receive a threaded end of the yo-yo axle. The yo-yo halves then are assembled by attaching them to the threaded ends of an axle that may include additional axle assembly components, such as bearings, bearing surfaces or the like.

In another aspect of the invention, the pattern in which the metal is deformed about the hub may be configured to modify the handling characteristics of the yo-yo. The configuration of the pattern may include an arrangement in which a plurality of radially extending raised ribs are formed that extend inwardly beyond the surface of the undeformed

portion of the disc or, in a further embodiment, as may be desired by some players, the pattern omits the starburst rib configuration and instead employs an arcuate recess formed in the inwardly facing surface of the disc. The recess extends circumferentially about the hub and serves to facilitate catching of the string on the yo-yo in a manner that may be considered to provide a smoother feel to catching of the string when the yo-yo is retrieved. Such a recess may also be used with molded plastic yo-yos or the like and is not limited only to metal yo-yos.

Among the objects of the invention are to provide a metal yo-yo and method for its manufacture that results in substantial economies; to provide a metal yo-yo in which each yo-yo half is formed from a separately formed disc and hub; to provide a metal yo-yo having a butterfly configuration; to provide a metal yo-yo in which the machining and finishing operations are minimized; to provide a metal yo-yo construction in which the components of the yo-yo can be processed in batches; to provide a process for manufacturing such a yo-yo and to provide a yo-yo construction in which the characteristic feel of the yo-yo, particularly during the yo-yo return, may be modified. Also among the objects of the invention is to provide a yo-yo construction in which the inwardly facing surfaces of the yo-yo halves are configured to facilitate catching of the string when retrieval is initiated without the use of radially extending or starburst-patterned members.

DESCRIPTION OF THE DRAWINGS

The foregoing and other objects and advantages of the invention will be appreciated more fully from the following further description thereof, with reference to the accompanying drawings wherein:

FIG. 1 is a diagrammatic illustration, in quarter section, of a prior art metal yo-yo in which the halves have a one-piece machined construction;

FIG. 2 is an illustration similar to FIG. 1, of a yo-yo made in accordance with the invention;

FIG. 3 is an illustration of a single flat disc that has been die cut from a sheet of metal;

FIG. 4 is an illustration of a disc that has been stamped to deform it to a peripherally flared configuration;

FIG. 5 is an enlarged quarter section illustration of the hub;

FIG. 6 is an illustration of the inner end of the hub as seen from the right of FIG. 5;

FIG. 7 is an illustration of the inner face of an assembled yo-yo half after the inner surface of the disc has been swaged;

FIG. 8 is a sectional illustration of the region of the swaging as seen along the line 8—8 in FIG. 7;

FIG. 9 is an enlarged full section illustration of the assembled yo-yo;

FIG. 10 is a further enlarged sectional illustration of a connection between the hub and the disc of a yo-yo half;

FIG. 11 is an illustration of a portion of the inner face of an assembled yo-yo half with the inner surface of the disc having been swaged in a pattern that leaves an arcuate or annular recess to provide a different characteristic feel for the yo-yo player;

FIG. 12 is a sectional illustration of the region of the juncture of the hub and disc of the embodiment of FIG. 11 as seen along the line 12—12 of FIG. 11; and

FIG. 13 is a fragmented, somewhat diagrammatic illustration of a yo-yo illustrating the presence of an annular

groove or recess defined in the inner face of the yo-yo half circumscribing the axle of the yo-yo.

DESCRIPTION OF THE PREFERRED EMBODIMENT

FIG. 1 illustrates a metal yo-yo having a prior art construction in which each of the yo-yo halves **10**, **12** is machined in one piece from metal bar stock. Each yo-yo half **10**, **12** may be formed on a milling machine that exposes an end of round bar stock, for example, of aircraft grade aluminum. The outer end face of the bar stock is milled to remove a substantial amount of material leaving an annular region **14** that encompasses and defines a hub **16** and a peripheral rim **18**, connected by a web **20**.

The outer peripheral surface **22** of the rim also may be machined to a desired contour. The inner face **24** of each yo-yo half may be formed so that when mated with an identical yo-yo half, the inner faces **24** will define a string slot **26** as desired, for example, with the more radially inwardly disposed regions of the slot defining a narrower space than the more outwardly disposed regions. A hole **28** then is drilled and tapped at the inner face **24** of each yo-yo half. The threaded hole is adapted to receive the threaded end of an axle **30** by which the two yo-yo halves **10**, **12** may be secured together. The axle hole **28** extends into the outwardly projecting hub **16** of the yo-yo half. The axle **30** may be part of an assembly that includes an appropriate bearing arrangement, indicated generally at **32** and may be a ball bearing or a bearing arrangement as that described in U.S. Pat. No. 4,895,547, the disclosure of which is incorporated by reference herein, in its entirety. Before assembly, a number of processes may be performed to enhance the appearance of the yo-yo, such as polishing, painting, graphic finishing, anodizing or the like. Where the yo-yo halve is machined from a single piece of material, as in the prior art described above, it does not lend itself to batch treatment with other yo-yo halves and can be expected to require individual finishing and fabrication. That, coupled with the expense of machining individual yo-yo halves, including the waste of material, results ultimately in a yo-yo that necessarily is very costly as compared to a yo-yo made from more conventional materials (e.g., plastic).

FIG. 2 illustrates a metal yo-yo embodying one aspect of the invention. The yo-yo includes yo-yo halves **34**, **36**. The axle **30** and bearing arrangement **32** may be similar to or the same as that used in the embodiment of FIG. 1, a ball bearing being preferred. The yo-yo halves **34**, **36**, however, are fabricated from two components, a disc **38** and a hub **40**, that are formed separately and then are combined and secured together to form the finished yo-yo half. The construction of the yo-yo half and its process for manufacture enables such yo-yos to be fabricated economically with a resultant cost substantially less than that of the type of yo-yo shown in FIG. 1.

FIG. 3 illustrates a disc **38** in its flat configuration after it has been cut, as by die cutting, from a flat sheet of material, preferably aluminum. A plurality of such discs can be die cut simultaneously from a flat sheet or strip of aluminum in a single die cut procedure. By way of example, an aluminum sheet 0.125 inch thick formed from an alloy that lends itself to being die cut and deformed (e.g., No. 3003-1114) may be cut to define discs with an outer diameter of 2.25 inches and having a center hole **42** about 0.50 inch in diameter. The sharp corners defined at the die break preferably are rounded slightly by machining or by using a progressive die cutting tool to coin the die break.

FIG. 4 illustrates the disc 38 after it has been stamped in stamping dies (not shown) to deform the outer peripheral margin 44 of the disc to flare outwardly, defining somewhat of a dished shape. The disc 38, having been formed from a uniform thickness sheet, thus can be stamped to simultaneously define the shape and contour of the inner and outer faces 46, 48 of the yo-yo half. The contour of the stamping dies may be selected to control the configuration of the string slot 50 (FIG. 2) and may be formed to include a substantial flare by which a butterfly-configured yo-yo will be formed when the yo-yo is assembled. Thus, the contour of the outer and inner faces 46, 48 can be formed simultaneously in a simple inexpensive operation in which there is minimal waste of material. Additionally, by embodying the foregoing construction and process, after the discs have been stamped, they may be polished in a batch (e.g., several hundred at a time) as by tumbling with an appropriate polishing grit to prepare the surface for further finishing, as desired. Where the disc is formed to its desired contour by bending, without machining, it does not have the machining marks that result from the prior art milling process and may be considered as already in a semi-finished state even before polishing.

FIGS. 5 and 6 illustrate the preferred embodiment of a hub adapted for secure connection to the formed disc to complete the structure of the yo-yo half. The hub, indicated generally at 40, may be formed from an aluminum alloy that lends itself to fabrication in an automatic screw machine, No. 2011 aluminum, being preferred. Such hubs 40 can be produced inexpensively and in substantial quantities, as on a Davenport multi-spindle automatic screw machine. The hub 40 includes an outer end 54 that will project outwardly into the dished region defined by the outer face 48 of the disc 38 after the parts are assembled. The hub 40 has an inwardly facing annular margin 56 with a diameter greater than that of the center hole 42 in the disc. When the hub 40 is assembled with a disc, the margin 56 of the hub 40 will bear firmly against the outer face 48 of the disc 38 in the marginal region about the center hole 42. The inner end of the hub is formed to include a projection 58 adapted to be closely fitted into the center hole 42 of the disc 38. The projection 58 is formed to include a locking band 60 having an outer peripheral surface 61 defined by a knurled pattern (e.g., a straight knurl of 128 diametral pitch) that can be fitted into the center hole 42 of the disc 38. The outer diameter of the locking band 60 is closely fitted to the diameter of the center hole 42 so that the two parts can be mated with relatively light force. So mated, the hub and disc, in the preferred embodiment, then are secured firmly together by deforming the inner face of the disc, as by impacting or stamping, with a die configured to form a plurality of impressions circumferentially spaced about the central axis of the yo-yo. The stamping serves to swage the disc to cause the metal of the disc to flow radially inward toward the central axis of the disc to constrict the disc tightly about the knurled surface of the locking band 60. A circumferential groove 64 preferably is formed between the inner face 56 of the outer end of the hub 40 and the outwardly facing surface 66 of the locking band 60. The groove 64 serves to provide space into which some of the metal (suggested at 63 in FIGS. 9 and 10) of the disc may cold flow as a result of the swaging operation. The deformed metal about the center hole 42 of the disc may flow into the groove 64 and engage the outer surface 66 of the locking band sufficiently to provide additional security to resist axial separation of the hub and the disc.

The swaging deforms the metal in a radially inward direction and may be done in a manner that causes the formation of a plurality of radially extending slightly raised

ribs 88 that may be arranged in somewhat of a starburst pattern (FIGS. 7-10). The alternating ribs and depressions 88, 86 provide a less smooth annular surface that can enhance the ability of the string to become frictionally bound in the string slot near the axle of the spinning yo-yo when the yo-yo is manipulated to release tension on the string to initiate return of the yo-yo to the player.

FIGS. 11 and 12 illustrate a modified arrangement in which the swaging of the metal of the disc, to secure it to the hub 40, employs a pattern of a continuous recess or groove 90 impressed in the inner face 46 of the disc 38. The annular groove 90 defines a radially extending annular flat 92 and an inwardly extending circumferential wall 94 that defines a transition from the annular flat 92 of the groove 90 to the inner face 46 of the disc 38. The wall 94, in turn, may define a circular edge 96 at its juncture with the inner face 46 of the disc 38. The edge 96 may be chamfered or the circumferential wall 94 may be otherwise configured to reduce the risk of abrasion of the string by the edge 96. By impacting the assembled hub 40 and disc 38 with a swaged pattern as defined by the annular groove, the hub 40 is secured to the disc 38 with some of the metal (indicated at 63) of the disc cold flowing into the locking groove 64. In addition to serving to swage the disc 38 to the hub 40, the formation of the annular recessed groove 90, including circumferential wall 94 on the inner surface 46 of the disc 38, provides a continuous annular recess in which the slackened yo-yo string may randomly bind when tension on the string is momentarily released to return the yo-yo to the user's hand. It is believed that the bunching together of the slackened string is promoted by engagement of the slack-end string with the circumferential wall 94 or the transition of the annular groove 90 in a manner that facilitates binding of the string to cause the yo-yo to return.

It should be understood that although the use of an annular groove pattern on the inner face of the yo-yo about the region of the axle or axle assembly has been described in connection with a metal yo-yo in which a yo-yo half is formed from a disc and a hub that are swaged together, this aspect of the invention may be used with other yo-yos formed from other materials, such as molded plastic.

FIG. 13 illustrates, diagrammatically, the inner face 24 of a yo-yo half 10 in which an annular recess 90' is defined circumferentially about the region of the axle or axle assembly. By way of example, and independently of the manner in which the yo-yo is formed, the annular recess preferably is of the order of 0.015 inch deep (below the surface of the inner face of the yo-yo half). The depth of the recess should not be more than the effective diameter of the yo-yo string (on the order of about 0.050 inch diameter) and preferably is about one-third of the string diameter. The total space between the inwardly facing flats 92' of the annular recesses 90' of the two yo-yo halves, in an assembled yo-yo in accordance with the invention, should not be greater than about 0.200 inch and, preferably is closer to the order of 0.130 inch. The outer diameter of the annular recess 90' preferably is of the order of 0.650 inch although satisfactory results can be achieved with an outer diameter of about three-quarters of an inch. The inner radius of the annular recess 90' may extend in proximity to the outer surface of the bearing 32', although the space between the bearing and the yo-yo halves 10', 12' should be small enough to prevent the string from becoming caught in such space.

The assembled yo-yo preferably includes a bearing assembly 32 to which the yo-yo string can be attached which permits the body of the yo-yo to spin with reduced frictional losses. FIG. 9 illustrates a ball bearing assembly that

includes an inner race **80** and an outer race **82**. The inner race has a central hole **75** that receives the axle **30** of the yo-yo. The inner surface of the hub **40** is configured to engage securely the inner race **80** so that the yo-yo and inner race **80** can spin relative to the outer race **82** that will be maintained stationary at the end of the string while the yo-yo is "sleeping". To that end, inner surface of the hub **40** is provided with an annular groove **72** that defines the outer periphery of a circular land **74**. The land **74** is dimensioned to engage and clamp against the lateral side of the inner race **80** of the bearing. The radial dimension of the annular groove is large enough to receive the outer race **82** of the bearing without interfering with the ability of the outer race to spin about the axle of the yo-yo. A hole **76** is formed axially in the hub **40** and is counter-bored at its inner end at **78**. The hole **76** is threaded to securely engage the threaded end of the axle **30**. The foregoing arrangement enables the yo-yo to be assembled by placing a bearing assembly **32** on the axle and then screwing the assembled yo-yo halves onto the opposite ends of the axle. As the yo-yo halves are screwed together, they will be drawn closer together until their lands **74** engage the opposite sides of the inner race **80** of the bearing assembly, thus clamping the inner race **80** between the lands **74** of the hubs **40**. So assembled, the axle, yo-yo halves, and inner race spin as a unit relative to the outer race **82**, the yo-yo string being attached to the outer race. The dimensions of the land **74** and groove **72** are selected with respect to the bearing assembly **32** to permit the foregoing mode of operation as well as to define the width of the string slot between the two yo-yo halves.

The location and shape of the flared outer annular margin of the discs can be varied to vary the overall width of the yo-yo that, in turn, affects the feel of the yo-yo in the user's hand. The shape of the flared portion also may be varied in order to provide variance in the configuration of the entry to the string slot. In a preferred embodiment the disc is formed from aluminum sheet 0.125 inches thick and has a diameter of about 2¼ inches and a central hole 0.500 inches in diameter. The radially inner region of the disc may be substantially planar or may be provided with a slight deformity to provide a slight taper to the string slot. The peripherally flared portion of the disc preferably begins at about 0.825 inches radially outwardly of the central axis of the disc and preferably is provided with a relatively smooth, progressive curve that results in a total width of the stamped disc (measured axially) of about 0.45 inches. When the yo-yo is assembled, it may be configured so that it will have a string slot width of about slightly less than 1/8th inch (e.g., 0.100") with an overall yo-yo width of approximately 1 inch. Thus, the arrangement can provide a very wide butterfly entry at the outermost periphery of the assembled yo-yo, of approximately 1 inch, that progressively narrows to the string slot. When performing string tricks, the wide entry afforded by the butterfly configuration makes it easier for the user to catch the yo-yo between the ends of a length of the yo-yo string. It should be understood, however, that although the foregoing dimensional example is a presently preferred configuration, other dimensions for the various components may be employed without departing from the scope of the invention.

After each yo-yo half is assembled and may have been polished in a batch process, it may be coated to apply a finishing coat as desired. A preferred finishing process may comprise applying a powder coat with the desired coloring in a conventional electrostatic process in which the piece then is baked at an elevated temperature to cause the powder to form the desired finish surface.

From the foregoing it should be appreciated that the invention provides a yo-yo structure and method for its construction that enables a metal yo-yo to be made with less difficulty and at substantially less expense than with prior art metal yo-yos. The construction and method of fabrication enables substantial variation in the configuration of the yo-yo. It also should be appreciated that the invention provides a configuration for the inwardly facing surfaces of a yo-yo in which a circumferentially extending recess is disposed about the axis of rotation to provide a modified arrangement for catching the string when the yo-yo is retrieved. It should be understood, however, that the foregoing description of the invention is intended merely to be illustrative thereof and that other modifications, embodiments and equivalents may be apparent to those skilled in the art without departing from its principles.

Having thus described the invention what I desire to claim and secure by Letters Patent is:

1. A pair of yo-yo halves, each yo-yo half having an inwardly facing surface and an outwardly facing surface, each yo-yo half being formed by separate metal disc and metal hub components secured to each other;
 - an axle connected at each of its ends to one of the yo-yo halves, the inwardly facing surfaces of the yo-yo halves being spaced from each other to define a string slot;
 - the hub being secured to its associated disk by compression of the disc about a portion of the hub, said compression being effected by swaging an annular region of the disc sufficiently to define an annular depression in the disc and cause metal of the disc to cold flow into secure engagement with a portion of the hub.
2. A metal yo-yo as defined in claim 1 further comprising: the inwardly facing surface of each disc being swaged to define an annular groove disposed circumferentially about radially inward portions of the disc to enhance the strength of the connection between the disk and the hub.
3. A yo-yo as defined in claim 2 wherein the annular groove has an annular flat and a circumferential wall.
4. A yo-yo as defined in claim 3 wherein the depth of the groove is not greater than the diameter of a yo-yo string.
5. A yo-yo as defined in claim 1 wherein the radial width of the annular depression is greater than its depth.
6. A yo-yo as defined in claim 3 wherein the transition from the circumferential wall to the inwardly facing surface of its associated yo-yo half is configured to reduce the risk of abrasion of a string in the region of the transitional surface between the annular recess and the inwardly facing surface of the yo-yo half.
7. A yo-yo as defined in claim 1 wherein the depth of the depression is about one-third the diameter of a yo-yo string.

* * * * *